

PowerPAR™ 575

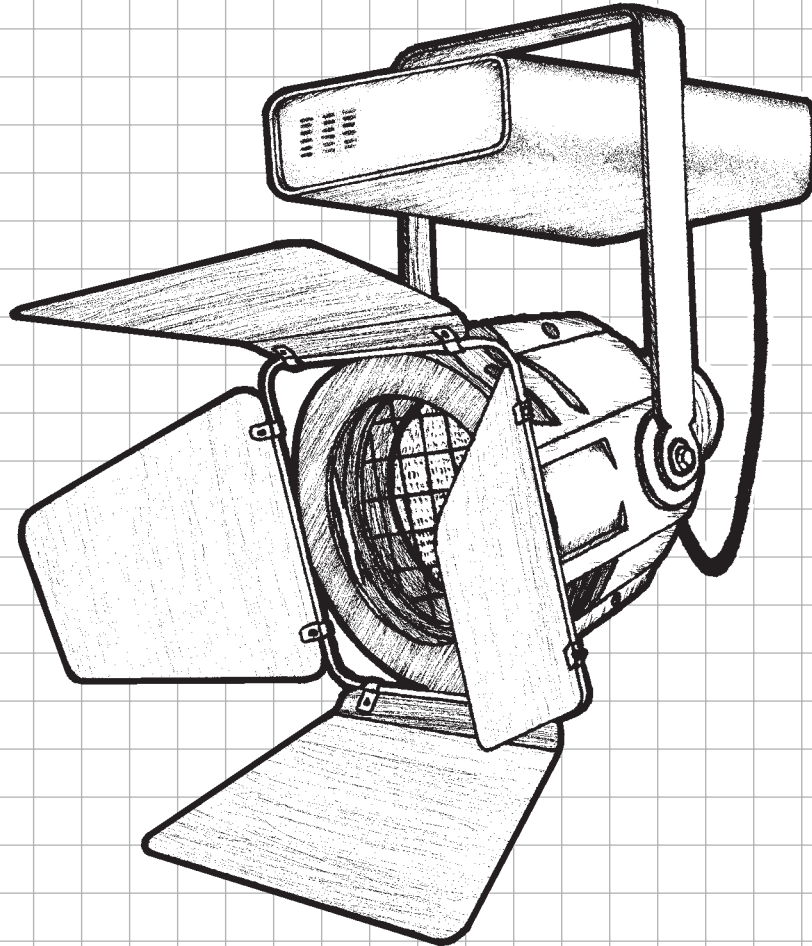

A high intensity discharge lamp in a modified ETC Source Four PAR™ body. Extremely bright, daylight output in a convenient, attractive package. The output of an HMI fixture with the field quality and versatility of the Source Four PAR™.

Source Four PAR is a registered trademark of Electronic Theatre Controls.



LOS ANGELES

10643 Glenoaks Blvd.
Pacoima, CA 91331
USA

Tel: +1 818.899.8818
Fax: +1 818.899.8813

LONDON

2 Commerce Road
Brentford, Middx TW8 8LR
UK

Tel: +44 (0)20.8560.9652
Fax: +44 (0)20.8560.1064

NEW YORK

100 Asia Place
Carlstadt, NJ 07072
USA

Tel: +1 201.896.8600
Fax: +1 201.896.8601

BEIJING

Unit 4, Blk 7, Shizipo
Dongzhimenwai
Dongcheng District
Beijing, China 100027

Tel: +86 10.6417.2286
Fax: +86 10.6415.9475

TORONTO

409 Saddler St. West
Box 654, Durham
Ontario N0G-1R0

Tel: +1 519.369.9990
Fax: +1 519.369.9992

PowerPAR™ 575 SPECIFICATIONS

TECHNICAL

PowerPAR 575 Auto Re-strike	
LIGHT SOURCE	575W single ended metal halide source with GX9,5 base and LCL=65mm. Applicable lamps include MSR575/2, HSR575/2, MSD575 and HSD575.
COLOUR TEMPERATURE	7200° K with MSR575/2 or HSR575/2. 6000° K with MSD575 or HSD575.
OPTICAL SYSTEM	Parabolic reflector with a faceted surface in combination with interchangeable beam shaping lenses.
COOLING	Convection cooled lamphouse, fan cooled ballast.
BALLAST TYPE	Electronic switch-mode power supply.
OPERATING VOLTAGE	Autosensing 90-265V AC, 47-65 Hz
POWER FACTOR	0.99 - Auto Correcting
POWER CONSUMPTION	690 VA (3A @ 230V)
MAX. SURFACE TEMP.	170° C
MAX. AMBIENT TEMP.	35° C
IP RATING	IP20
MOUNTING	Standard 12.5 mm hole on top of yoke for clamp mounting
OPERATING ANGLE	Unrestricted
FINISH	Matte black finish standard. Custom finishes are available for a reasonable surcharge and lead time.
ACCESSORIES	PowerPAR 575 is supplied with a set of four lenses, a colour frame, and a 4-leaf rotatable barndoor. Additional accessories are available including top-hats, half-hats, eggcrate louvers and various mounting hardware.

PHOTOMETRIC

LENS TYPE	ANGLE	INTENSITY	MULTIPLIER	10'		20'		30'		40'		50'		60'	
	BEAM	CANDELA	BEAM	FOOT CAND.	BEAM DIAM.	FOOT CAND.	BEAM DIAM.	FOOT CAND.	BEAM DIAM.	FOOT CAND.	BEAM DIAM.	FOOT CAND.	BEAM DIAM.	FOOT CAND.	BEAM DIAM.
	FIELD		FIELD	LUX	FIELD DIAM.	LUX	FIELD DIAM.	LUX	FIELD DIAM.	LUX	FIELD DIAM.	LUX	FIELD DIAM.	LUX	FIELD DIAM.
VNSP (clear)	11°	752000	0.2	7520	2	1880	4	836	6	470	8	301	10	209	12
	20°		0.36	80945	3.6	20236	7.2	8994	10.8	5059	14.4	3238	18	2248	21.6
NSP (stipple)	13°	616000	0.23	6160	2.3	1540	4.6	684	6.9	385	9.2	246	11.5	171	13.8
	23°		0.41	66306	4.1	16576	8.2	7367	12.3	4144	16.4	2652	20.5	1842	24.6
MFL (8-row)	15° x 20°	356000	0.31 x 0.37	3560	3.1 x 3.7	890	6.2 x 7.4	396	9.3 x 11.1	223	12.4 x 14.8	142	15.5 x 18.5	99	18.6 x 22.2
	23° x 30°		0.41 x 0.56	38320	4.1 x 5.6	9580	8.2 x 11.2	4258	12.3 x 16.8	2395	16.4 x 22.4	1533	20.5 x 28	1064	24.6 x 33.6
WFL (12-row)	18° x 28°	152000	0.32 x 0.52	1520	3.2 x 5.2	380	6.4 x 10.4	169	9.6 x 15.6	95	12.8 x 20.8	61	16 x 26	42	19.2 x 31.2
	35° x 45°		0.62 x 0.84	16361	6.2 x 8.4	4090	12.4 x 16.8	1818	18.6 x 25.2	1023	24.8 x 33.6	654	31 x 42	454	37.2 x 50.4

To calculate intensity in footcandles at any given distance, divide the candela number by the throw squared.

To calculate beam or field diameter, multiply the "Beam" or "Field" multiplier by the throw.